

## Matchable Pairs – Emitter and Detector

### Description

Pairs of infrared-emitting diode and phototransistor, matched in their optical and electrical features. These pairs enable a lot of applications. They can be used both for transmissive or reflective sensor functions. The peak wavelength of the emitter is  $\lambda = 950 \text{ nm}$ .

### Applications

Generally used for industrial processing and controlling, end of tape detector

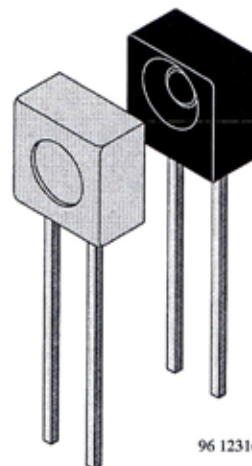

### Features

- Miniature case with lens
- Detector with optical filter, protected against ambient light
- Detector case black for easy identification of the emitter and detector
- Emitter-angle of half-intensity  $\pm\varphi = 35^\circ$
- Detector-angle of half sensitivity  $\pm\varphi = 35^\circ$
- Emitter and detector in sideview case
- Selected in groups for matching pairs

## Absolute Maximum Ratings

### Emitter – V472P

Parameters	Test Conditions	Symbol	Value	Unit
Reverse voltage		$V_R$	6	V
Forward current		$I_F$	60	mA
Forward surge current	$t_p \leq 10 \mu\text{s}$	$I_{FSM}$	1	A
Power dissipation	$T_{amb} \leq 25^\circ\text{C}$	$P_V$	100	mW
Junction temperature		$T_j$	100	$^\circ\text{C}$
Operating temperature range		$T_{amb}$	-40 to +85	$^\circ\text{C}$
Storage temperature range		$T_{stg}$	-40 to +100	$^\circ\text{C}$
Soldering temperature	2 mm from case, $t \leq 5 \text{ s}$	$T_{sd}$	260	$^\circ\text{C}$

### Detector – S472P

Parameters	Test Conditions	Symbol	Value	Unit
Collector emitter voltage		$V_{CEO}$	70	V
Emitter collector voltage		$V_{ECO}$	7	V
Collector current		$I_C$	50	mA
Collector peak current	$t_p/T = 0.5, t_p \leq 10 \text{ ms}$	$I_{CM}$	100	mA
Power dissipation	$T_{amb} \leq 25^\circ\text{C}$	$P_V$	150	mW
Junction temperature		$T_j$	100	$^\circ\text{C}$
Operating temperature range		$T_{amb}$	-40 to +85	$^\circ\text{C}$
Storage temperature range		$T_{stg}$	-40 to +100	$^\circ\text{C}$
Soldering temperature	2 mm from case, $t \leq 5 \text{ s}$	$T_{sd}$	260	$^\circ\text{C}$

### Basic Characteristics ( $T_{amb} = 25^\circ\text{C}$ )

#### Emitter – V472P

Parameters	Test Conditions	Symbol	Min.	Typ.	Max.	Unit
Forward voltage	$I_F = 50 \text{ mA}$	$V_F$		1.25	1.6	V
Junction capacitance	$V_R = 0, f = 1 \text{ MHz}$	$C_j$		50		pF
Radiant power	$I_F = 50 \text{ mA}, t_p \leq 20 \text{ ms}$	$\Phi_e$		5		mW
Temp. coefficient of $\Phi_e$	$I_F = 50 \text{ mA}$	$TK_{\Phi_e}$		-1		%/K
Angle of half intensity		$\varphi$		$\pm 35$		deg
Peak wavelength	$I_F = 50 \text{ mA}$	$\lambda_p$		950		nm
Spectral bandwidth	$I_F = 50 \text{ mA}$	$\Delta\lambda$		50		nm

### Detector – S472P

Parameters	Test Conditions	Symbol	Min.	Typ.	Max.	Unit
Collector emitter voltage	$I_C = 1 \text{ mA}$	$V_{CEO}$	70			V
Emitter collector voltage	$I_C = 100 \mu\text{A}$	$V_{ECO}$	7			V
Collector dark current	$V_{CE} = 25 \text{ V}, I_f = 0, E = 0$	$I_{CEO}$			100	nA
Angle of half sensitivity		$\varphi$		$\pm 35$		deg
Wavelength of peak sensitivity		$\lambda_p$		920		nm
Range of spectral bandwidth		$\lambda_{0.5}$		850...980		nm
Collector emitter saturation voltage	$E_e = 1 \text{ mW/cm}^2, \lambda = 950 \text{ nm}, I_C = 0.1 \text{ mA}$	$V_{CEsat}$			0.3	V

## Type Decicated Characteristics

### Emitter – V472P

Parameter	Test Conditions	Type	Symbol	Min	Typ	Max	Unit
Radiant intensity	$I_F = 50 \text{ mA}$ , $t_p \leq 20 \text{ ms}$	A2	$I_e$	2.3		3.7	mW/sr
		B1	$I_e$	3.0		4.4	mW/sr
		B2	$I_e$	3.6		5.0	mW/sr
		B3	$I_e$	4.0		5.5	mW/sr
		B4	$I_e$	4.5		6.0	mW/sr

### Detector – S472P

Parameter	Test Conditions	Type	Symbol	Min	Typ	Max	Unit
Collector light current	$V_{CE} = 5 \text{ V}$ , $E_c = 1 \text{ mW/cm}^2$ , $\lambda_p = 950 \text{ nm}$	A2	$I_{ca}$	1.7		2.8	mA
		B1	$I_{ca}$	2.2		4.2	mA
		B2	$I_{ca}$	3.4		5.5	mA

## Switching Characteristics

Parameter	Test Conditions	Symbol	Min.	Typ.	Max.	Unit
Delay time	$V_S = 5 \text{ V}$ , $I_C = 5 \text{ mA}$ , $R_L = 100 \Omega$ (see figure 1)	$t_d$		1.8		$\mu\text{s}$
Rise time		$t_r$		1.6		$\mu\text{s}$
Fall time		$t_f$		1.7		$\mu\text{s}$
Storage time		$t_s$		0.3		$\mu\text{s}$
Turn-on time		$t_{on}$		3.4		$\mu\text{s}$
Turn-off time		$t_{off}$		2.0		$\mu\text{s}$

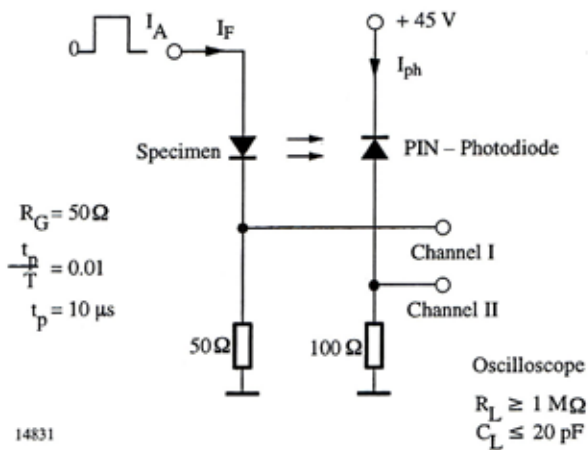

Figure 1. Test circuit Emitter

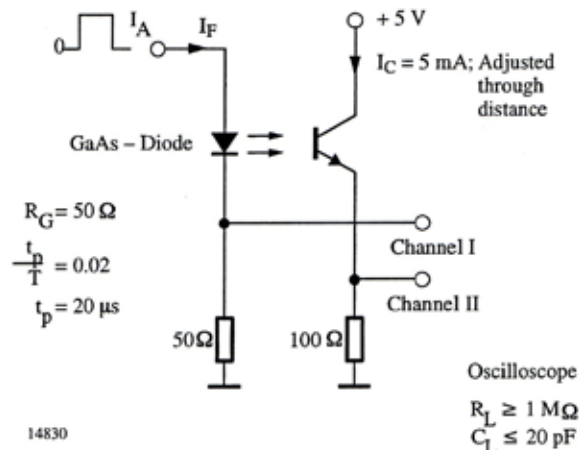

Figure 1. Test circuit Detector

## Matching Scheme

S472P

	A2	B1	B2
V	A2		x
4	B1	x	
7	B2	x	
2	B3	x	
p	B4	x	

x = accepted combination

## Typical Characteristics ( $T_{amb} = 25^{\circ}\text{C}$ , unless otherwise specified)

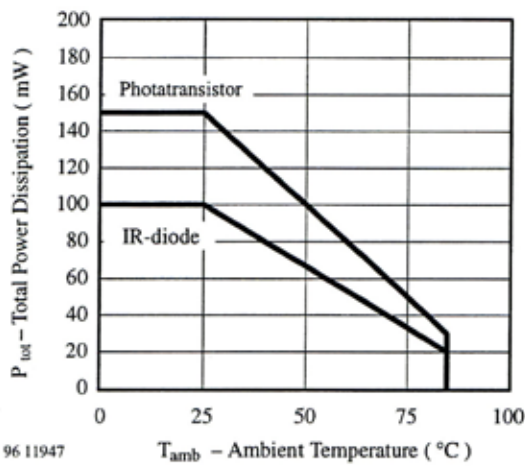

Figure 2. Total Power Dissipation vs. Ambient Temperature

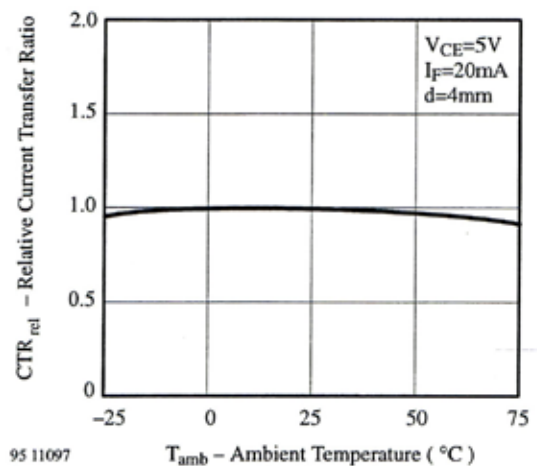

Figure 4. Rel. Current Transfer Ratio vs. Ambient Temperature

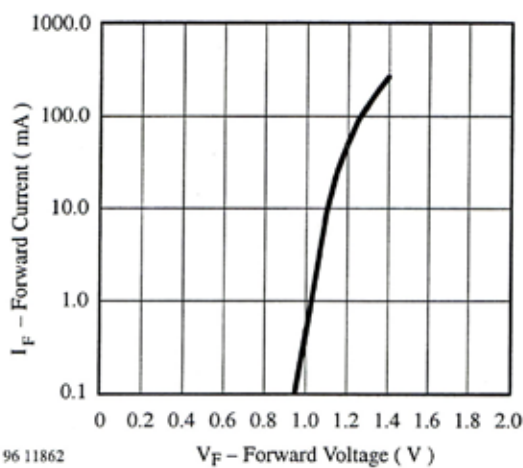

Figure 3. Forward Current vs. Forward Voltage

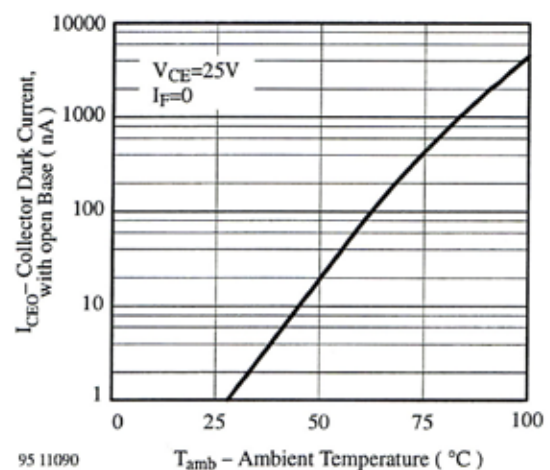

Figure 5. Collector Dark Current vs. Ambient Temperature



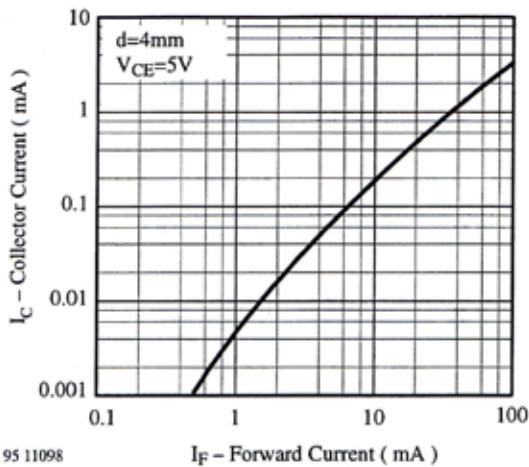

Figure 6. Collector Current vs. Forward Current

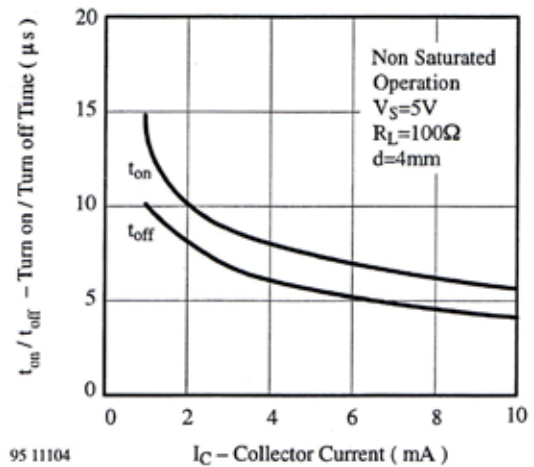

Figure 9. Turn on / off Time vs. Collector Current

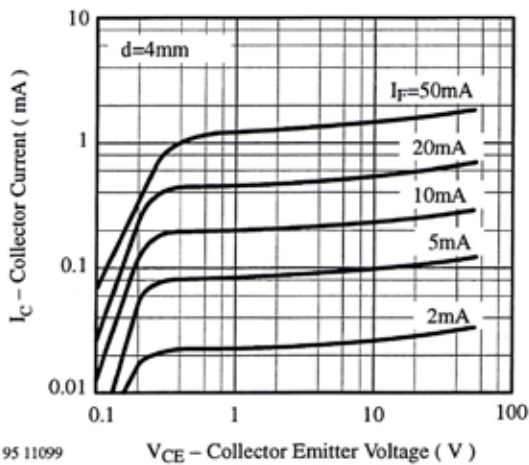

Figure 7. Collector Current vs. Collector Emitter Voltage

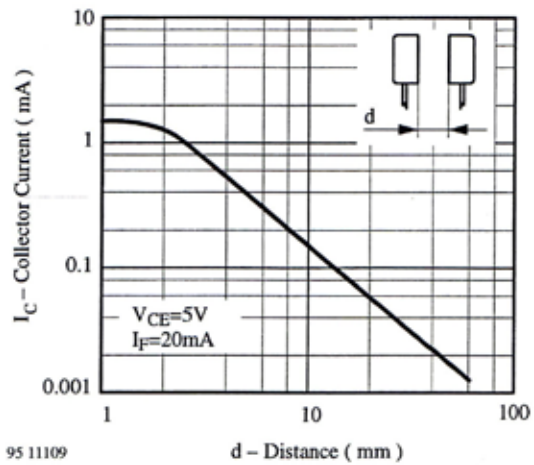

Figure 10. Collector Current vs. Distance

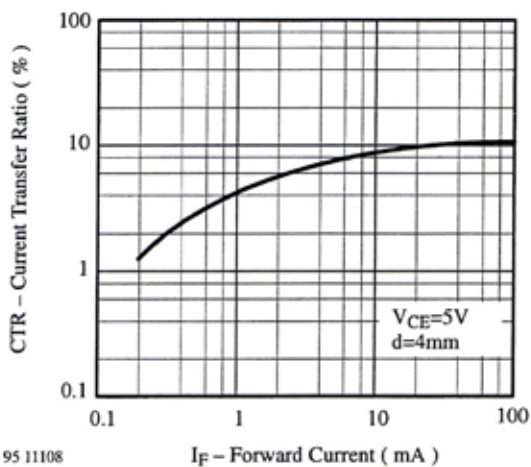

Figure 8. Current Transfer Ratio vs. Forward Current

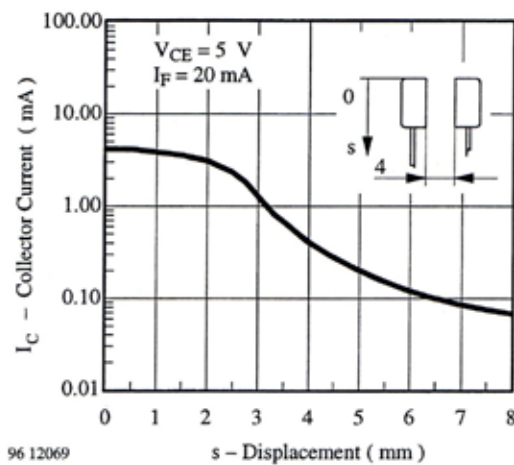
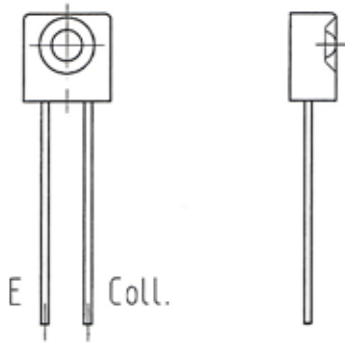
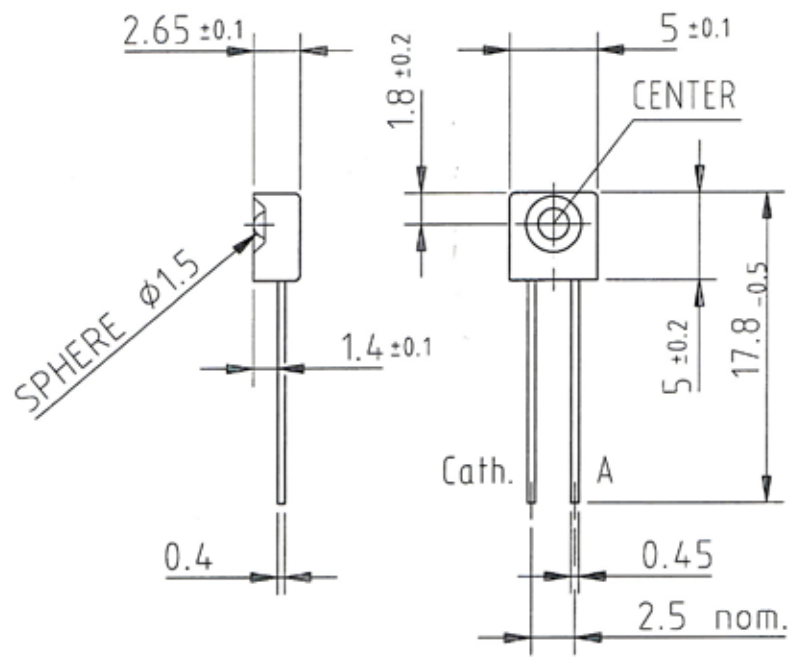

Figure 11. Collector Current vs. Displacement

**Dimensions in mm**



DETECTOR (BLACK)



EMITTER (CLEAR)



technical drawings  
according to DIN  
specifications

96 12105

weight: 0.25 g

---

## Ozone Depleting Substances Policy Statement

It is the policy of **TEMIC TELEFUNKEN microelectronic GmbH** to

1. Meet all present and future national and international statutory requirements.
2. Regularly and continuously improve the performance of our products, processes, distribution and operating systems with respect to their impact on the health and safety of our employees and the public, as well as their impact on the environment.

It is particular concern to control or eliminate releases of those substances into the atmosphere which are known as ozone depleting substances (ODSs).

The Montreal Protocol (1987) and its London Amendments (1990) intend to severely restrict the use of ODSs and forbid their use within the next ten years. Various national and international initiatives are pressing for an earlier ban on these substances.

**TEMIC TELEFUNKEN microelectronic GmbH** semiconductor division has been able to use its policy of continuous improvements to eliminate the use of ODSs listed in the following documents.

1. Annex A, B and list of transitional substances of the Montreal Protocol and the London Amendments respectively
2. Class I and II ozone depleting substances in the Clean Air Act Amendments of 1990 by the Environmental Protection Agency (EPA) in the USA
3. Council Decision 88/540/EEC and 91/690/EEC Annex A, B and C (transitional substances) respectively.

**TEMIC** can certify that our semiconductors are not manufactured with ozone depleting substances and do not contain such substances.

**We reserve the right to make changes to improve technical design and may do so without further notice.**

Parameters can vary in different applications. All operating parameters must be validated for each customer application by the customer. Should the buyer use TEMIC products for any unintended or unauthorized application, the buyer shall indemnify TEMIC against all claims, costs, damages, and expenses, arising out of, directly or indirectly, any claim of personal damage, injury or death associated with such unintended or unauthorized use.

TEMIC TELEFUNKEN microelectronic GmbH, P.O.B. 3535, D-74025 Heilbronn, Germany  
Telephone: 49 (0)7131 67 2831, Fax number: 49 (0)7131 67 2423